



GERAND ENGINEERING

9431 SCIENCE CENTER DRIVE, NEW HOPE MN 55428
952.374.1320 WWW.GERAND.COM

FIRE PUMP TEST METER

G-400-4

CONSTRUCTION & SPECIFICATIONS

- VENTURI: ZINC PLATED STEEL
- VALVES: ONE PIECE BRASS BODY
ZINC DIECAST STEEL HANDLE
- HOSES: 3/16" NYTRILE CORE, POLYESTER
BRAID AND EPDM SYNTHETIC COVER

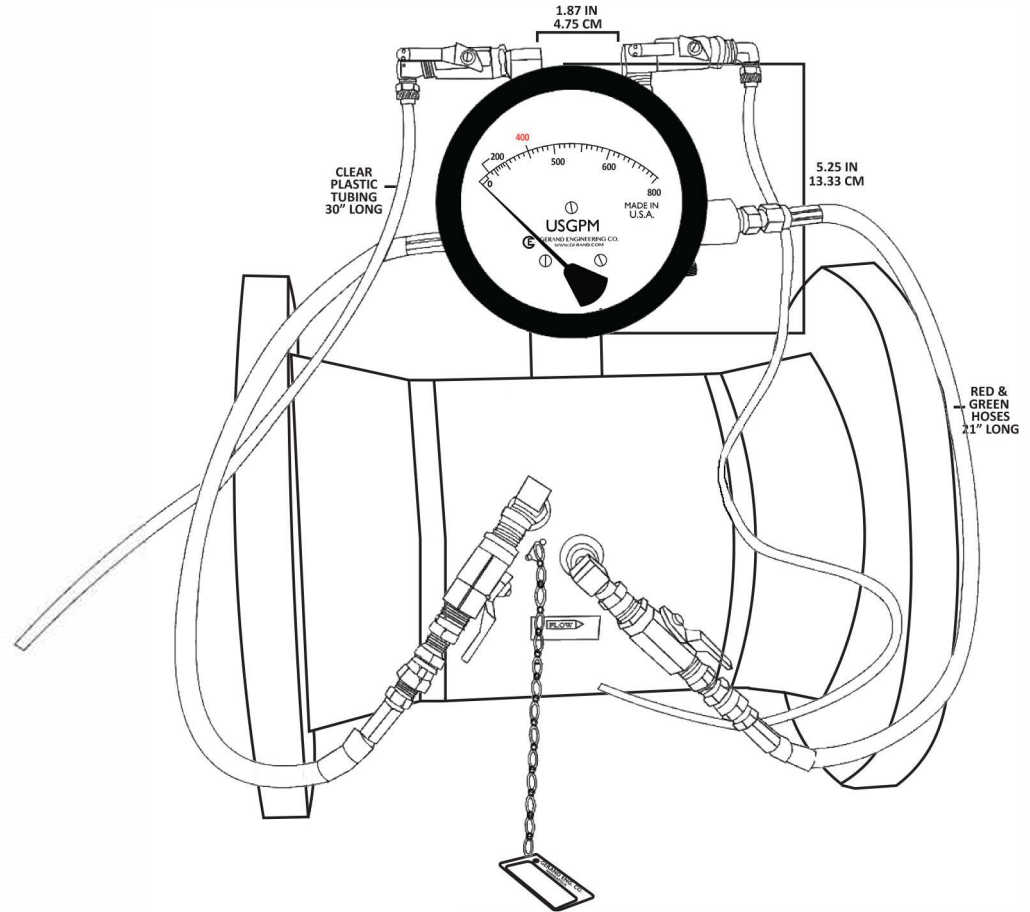

METER DATA

- CONSTRUCTION: ALUMINUM BODY
- OPERATION: BUNA "N" DIAPHRAGM
- ACCURACY: ±2.0%
- TEMPERATURE: 200° F MAX
- PRESSURE: 1500 PSI MAX
- APPROX. WEIGHT: 3 LBS/EACH

4 1/2" DIAL STANDARD - 6" AVAILABLE

WELD-NECK FLANGES
RAISED FACE

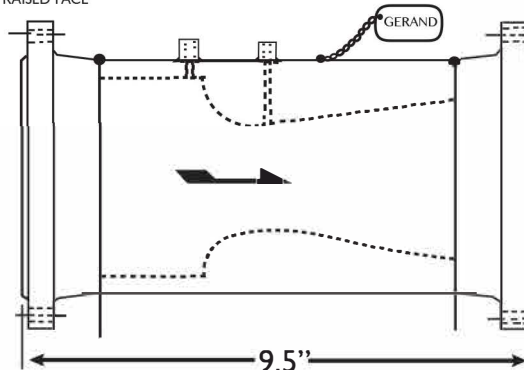

WEIGHTS & DIMENSIONS

- WEIGHT: 51 LBS
- SHIPPING DIMENSIONS: 13" x 13" x 21" BOX